

DOZER BLADE ASSEMBLY

ITEM NO.	PART NO.	DESCRIPTION	NO. REQ'D	ITEM NO.	PART NO.	DESCRIPTION	NO. REQ'D
Dozer Blade Assembly				21	I341	5/16-18 x 5 Eyebolt (Includes Item # 11)	1
1	I061	Spring (1-7/8 x 9)	1	Fasteners			
2	I064	Pivot Pin	1				
3	I060	1/4 x 1 Roll Pin	2				
4	I065	Adjustment Pin	1	F317	3/16 x 1 Split Spring Pin		1
5	I063	Female Quick Hitch	1	NOTE: Decals are illustrated in greater detail in the Owner's section of this manual. Refer to SAFETY, CONTROL, AND INSTRUCTION DECALS in Safety Instructions , Page 17.			
6	NS	Decal, Trip Spring Lockout (RAD 657503)	1	NOTE: All NS items are listed with a RAD Part Number (e.g., RAD 657383), and are not sold by Walker Manufacturing. To order these items, contact:			
7	I058	Hitch Box	1				
8	I059	3/4 x 17-3/4 Pin	1				
9	5800	Decal, Walker Mower (4 x 7-1/2)	1				
10	NS	Decal, Stay Clear Blade (RAD 657524)	2				
11	I050	Welded Blade	1				
12	O/L	5/16-NC Hex Nut	7				
13	O/L	5/16 Lock Washer	1				
14	I056	Skid Shoe Pin	2				
15	I055	Skid Shoe	2				
16	I057	3mm x 65mm Hairpin	3				
17	O/L	5/16-NC x 1 Carriage Bolt	6				
18	I051	Cutting Edge	1				
19	I068	Trip Spring Lockout Pin	1				
20	I067	Trip Spring Lockout	1				

DOZER BLADE ASSEMBLY

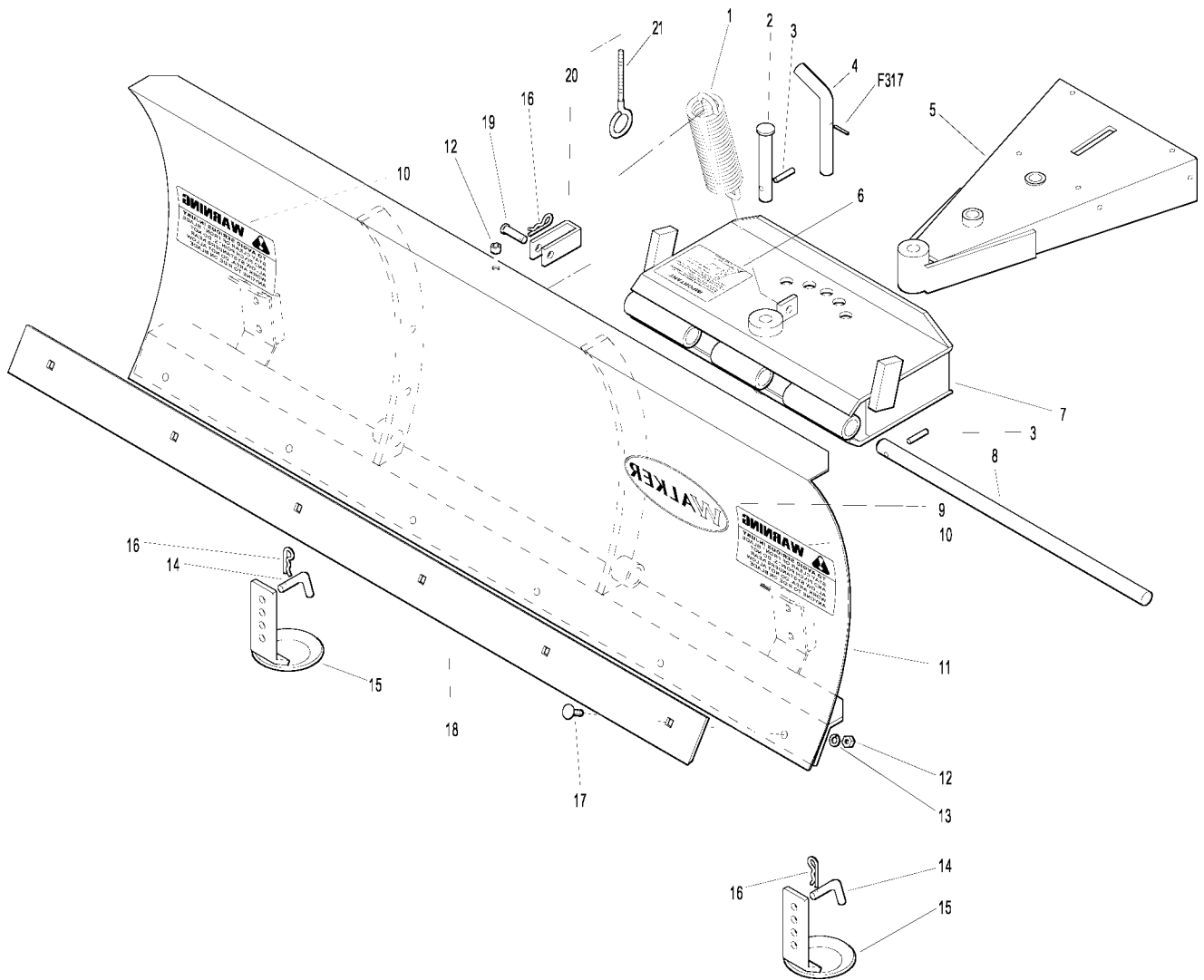

KEY TO ABBREVIATIONS USED IN ILLUSTRATED PARTS MANUAL

<i>Abbreviation</i>	<i>What it Represents</i>
° (Dimension)	Degrees (Angle)
" (Dimension)	inches
cfm	cubic feet per minute
cl	centiliters
cm	centimeters
Db	Decibels
DC	Direct Current
ESNA (Fastener)	Nylon Insert Locknut
fl. oz.	fluid ounces
FSC	Forward Speed Control
ft	feet
ft-lb	foot-pounds
GHS	Grass Handling System
GR (Fastener)	Grade
HP	Horse Power
ID	Identification or Inside Diameter
kg	kilograms
km/h or kph	kilometers per hour
kPa	kilopascals
lb	pounds
lbf	poundals or pounds force
LH	Left Hand (orientated with operator on seat)
m	meters
mm (Dimension)	millimeters
mph	miles per hour
N	Newtons
NC (Fastener)	National Coarse
NF (Fastener)	National Fine
NPT	National Pipe Thread
NS (as part number)	Item is not sold by Walker Manufacturing
N·m	Newton-meters
O/L	Obtain Locally (Item is not sold by Walker Manufacturing)
P/N	Part Number
PPHMS (Fastener)	Phillips Pan Head Machine Screw
PSI	Pounds Square Inch
PTO	Power Take-Off
RH	Right Hand (orientated with operator on seat)
RPM	revolutions per minute
SAE (Fastener)	Society of Automotive Engineers
SBH (Fastener)	Socket Button Head (Bolt)
S/N	Serial Number
U	Unified

NOTE: In some instances, combinations of abbreviations may be used (e.g. UNC - Unified National Coarse).